

Installation and Operating Instructions

Horizontal belt hopper

BU-W 5
BU-W 15
BU-W 25
BU-W 50
BU-W 100
BU-W 200

Table of Contents

| | | |
|--------|---|----|
| 1. | General | 4 |
| 1.1. | Dimensions | 4 |
| 1.2. | Technical data | 5 |
| 1.3. | Motor connection data | 5 |
| 2. | Safety directives..... | 6 |
| 2.1. | Applicable directives and standards..... | 8 |
| 3. | Design and functional description of belt hoppers..... | 8 |
| 4. | Shipment and installation | 9 |
| 4.1. | Shipment..... | 9 |
| 4.2. | Installation..... | 9 |
| 4.2.1. | Belts | 9 |
| 4.2.2. | Roller alignment | 10 |
| 4.2.3. | Drive system (belt hoppers without RNA control units) | 10 |
| 5. | Commissioning..... | 11 |
| 5.1. | Belt tracking adjustment..... | 11 |
| 5.2. | Adjustment of belt return station | 12 |
| 6. | Maintenance..... | 12 |
| 6.1. | Belt..... | 12 |
| 6.2. | Motor..... | 12 |
| 6.3. | Gearbox..... | 12 |
| 6.4. | Return, drive and supporting rollers | 12 |
| 6.5. | Environmental effects | 12 |
| 7. | Spare parts and customer service..... | 13 |



Declaration of Incorporation

according to Machinery Directive 2006/42/EC

We hereby declare that our product is intended to be incorporated into or assembled with other machinery to constitute one machine in terms of the Directive indicated above (or parts thereof) and that it must not be put into operation until the relevant machinery into which it is to be incorporated has been declared to be in conformity with the EC Machinery Directive.

Applied harmonised standards: DIN EN 60204 T1, DIN EN ISO 12100-2011-03, DIN EN 619, DIN EN 620

Remarks:

This product has been manufactured in accordance with the Low-Voltage Directive 2014/35/EU.

We assume that our product will be incorporated into a stationary machine.

Rhein-Nadel-Automation

Managing Director
Dr. Tobias Hensen



1. General

1.1. Dimensions

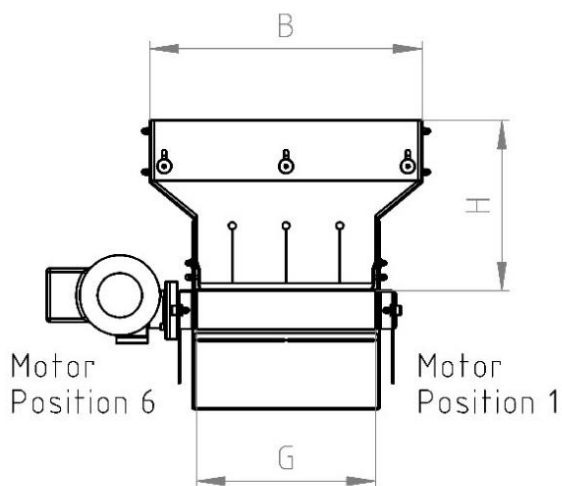
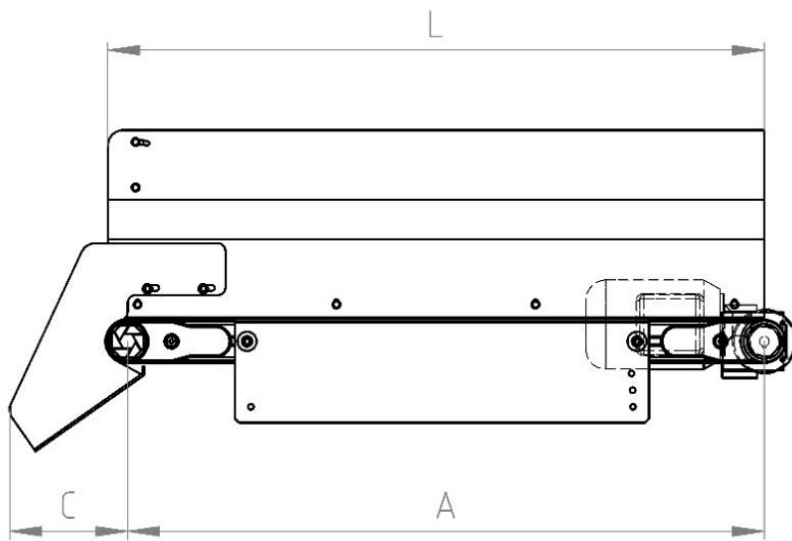

| Type | L | A | B1 | B2 | H | C |
|-----------------|------|------|-----|-----|-----|-----|
| BU-W 5 | 475 | 450 | 120 | 125 | 105 | 140 |
| BU-W 15 | 475 | 450 | 120 | 250 | 205 | 140 |
| BU-W 25 | 525 | 500 | 150 | 280 | 240 | 140 |
| BU-W 50 | 825 | 800 | 250 | 380 | 240 | 140 |
| BU-W 100 | 1025 | 1000 | 300 | 430 | 290 | 140 |
| BU-W 200 | 1025 | 1000 | 300 | 430 | 510 | 140 |

1.2. Technical data

| Belt hopper with three-phase motor | | | | | | |
|--|---|--------|--------|--------|---------|---------|
| Type | BU-W 5 | BU-W15 | BU-W25 | BU-W50 | BU-W100 | BU-W200 |
| Max. volumetric capacity in litres | 5 | 15 | 25 | 50 | 100 | 200 |
| Max. filling weight (kg) | 15 | 50 | 70 | 80 | 100 | 100 |
| Belt speed | 2 m/min | | | | | |
| Rated voltage | 230/400 V | | | | | |
| Current (A) | 0.37 | | | | | |
| Motor rating (W) | 90 | | | | | |
| Control: Motor protection breaker, interlocked | We recommend our EBB 1ZDS | | | | | |
| Motor position | Standard version has the motor on the right (viewed in conveying direction) | | | | | |

| Belt hopper with AC motor | | | | | | |
|--|---|--------|--------|--------|---------|---------|
| Type | BU-W 5 | BU-W15 | BU-W25 | BU-W50 | BU-W100 | BU-W200 |
| Max. volumetric capacity in litres | 5 | 15 | 25 | 50 | 100 | 200 |
| Max. filling weight (kg) | 15 | 50 | 70 | 80 | 100 | 100 |
| Belt speed | 2 m/min | | | | | |
| Rated voltage | 230 V | | | | | |
| Current (A) | 0.64 | | | | | |
| Motor rating (W) | 90 | | | | | |
| Control: Motor protection breaker, interlocked | We recommend our EBB 1ZS | | | | | |
| Motor position | Standard version has the motor on the right (viewed in conveying direction) | | | | | |

1.3. Motor connection data

Connecting diagram three-phase motor - Connection to 3-wire network

Connecting diagram three-phase motor
high voltage (Star connection)
3x400 V

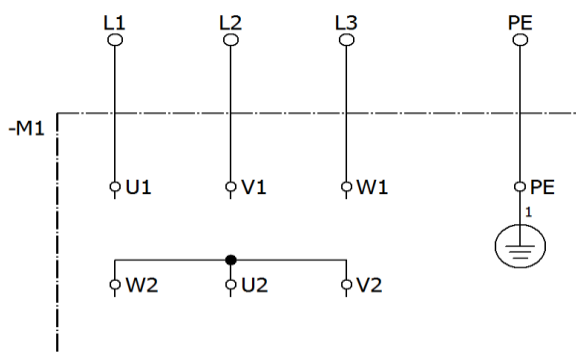

Connecting diagram three-phase motor
low voltage (Delta connection)
3x230 V

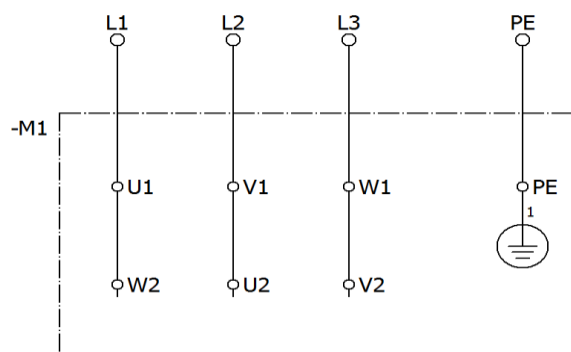

For reversing the sense of rotation change two phases of the supply line

Connecting diagram capacitor motor -

Connection to 2-wire network

Connection to the AC mains
1x230 V

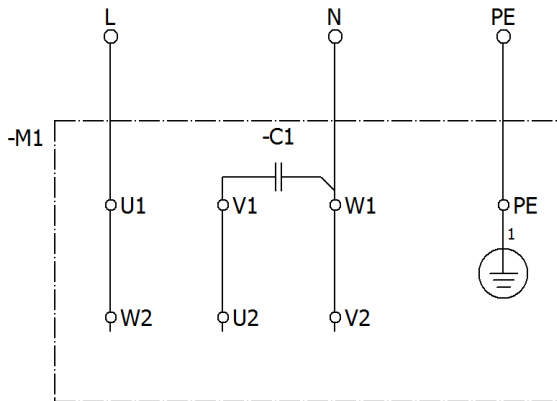

Clockwise rotation

Connection to the AC mains
1x230 V

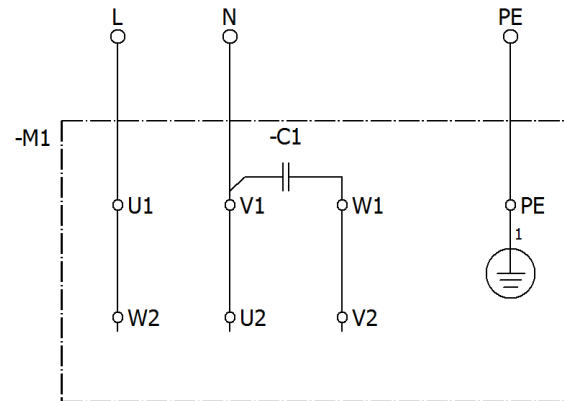

Counter-clockwise rotation

2. Safety directives

We have taken great care in design and manufacture of our conveyors in order to ensure smooth and safe operation. You, too, can make an important contribution towards safety at work. We therefore ask you to read these brief operating instructions completely prior to commissioning the system. Observe the safety directives at all times!



Attention

This warning sign indicates safety directives. Non-observance of such warnings may cause serious injury or even death!



Caution

This warning sign indicates safety directives. Non-observance of this warning may cause minor injury or material damage.



Notice

This symbol indicates useful tips for operation of the conveyors.

Make sure that all persons working with or at the equipment also read the following safety directives carefully and follow them!

These Operating Instructions only apply to the equipment types indicated on the cover page.

They must be available at all times at the place of installation of the conveyor.

If the conveyor is to be used in a humid or wet environment (wet area) make sure that the required degree of protection is provided.



Notice

For comprehensive information on the full range of control devices please refer to the 'Control Units' operating instructions.

Any commissioning, retooling, maintenance and repair work shall be carried out by qualified and authorized personnel only (see also 'Operator's duties' in this section).

For installation, maintenance and repair work all poles of the power supply must be disconnected from the conveyor in compliance with VDE provisions.

Any work on the electrical equipment shall be carried out exclusively by a professional electrician, or by instructed persons working under the supervision of a professional electrician, according to electrotechnical rules.



Attention

Risk of injury and electric shock hazard!

- The equipment user and operators shall ensure that only authorized personnel works at the conveyor.
- Any changes that have occurred on the feeding system affecting safety shall immediately be reported to the user.
- Operate the conveyor in perfect condition only.
- Use the belt conveyor only for its intended use.
- Observe the DGUV accident prevention regulations 100-500 chapter 2.09 for continuous conveyors and BGV A3 for electrical equipment and components!
- Make sure that protective earthing of the power supply system is in perfect condition.
- Never operate the conveyor without chain guards and cover panels in place!
- The gaps at the belt entry points must not be wider than 4 mm to prevent pinch point hazards. If the gap is wider than that after belt tracking adjustments, be sure to readjust the pinch guard.

Intended use

The intended use of the belt hoppers is the storage and feeding of parts.

The shortest side of such parts must be at least 5 mm long.



Caution

Smaller parts may get under the belt and cause damage or failure of the belt conveyor.

Parts handled with standard belts must be dry, clean and without sharp edges. The handling of sharp-edged, oily, wet or hot (>70°C) parts requires the use of special belts.

The parts must not drop on the conveyor belt from height. The maximum permitted impact energy is 0.1 J.

If in doubt, please contact the manufacturer.

The hopper belt conveyors are designed for horizontal transport of the maximum load of parts. A slight inclination of the conveyor is possible in some cases. Please consult the manufacturer to determine what is possible for your specific application!

For permitted belt loading see Technical Data in section 1.

Noise emission

The constant sound pressure level is 70 dB(A) max. Specific part handling applications or belt designs may result in higher noise levels. For such exceptional cases noise abatement options are available from manufacturer.

Equipment user's duties

Commissioning, retooling, maintenance and repair work shall be performed by qualified and authorized personnel only.

We distinguish between four qualification levels:

Qualified personnel

refers to persons who are familiar with installation, start-up and operation of the conveyor. Their qualifications are appropriate for their activities.

Authorized personnel

refers to qualified personnel that has been assigned a clearly defined task by the user of the belt conveyor.

Qualified electrical worker

According to IEC 364 and DIN VDE 0105 Part 1, the term 'qualified electrical worker' refers to persons who, through their professional training, know-how and experience and through their knowledge of applicable standards are able to assess the work assigned to them and to recognize potential hazards.

Instructed person

According to IEC 364 and DIN VDE 0105 Part 1, the term 'instructed person' refers to persons who have been instructed in the tasks assigned to them by a qualified electrical worker. These persons have also been briefed on potential dangers resulting from inappropriate behaviour, and on the requisite guards and precautions to be used/taken.

2.1. Applicable directives and standards

The hopper has been manufactured in accordance with the following directives:

- EC Machinery Directive 2006/42/EC
- EC Low-Voltage Directive 2014/35/EU
- Electromagnetic Compatibility Directive 2014/30/EU

We assume that our product will be incorporated into a stationary machine. The requirements of the EMC Directive must be satisfied by the user.

The applicable standards are specified in the Declaration of Incorporation.

3. Design and functional description of belt hoppers

Our belt hoppers are based on the RNA belt conveyor type FP120 with its body made up of a special grooved aluminium profile. The motor may be of the three-phase or AC type. It is used for direct drive and can be arranged at the left or right-hand side of the conveyor starting end.

The attachments such as hopper tray, sealing bars, exit chute and apron are made of 1.4301 stainless steel, externally brushed, and factory-assembled. Control of the belt hopper is effected, depending on motor type, by motor protection breaker, electronic control devices or variable-frequency control units.

Optionally, the hoppers are fitted with a quick emptying flap at the rear or with a hinged hopper cover. For emptying the hopper, open the side clamps and then open the flap until it is held by the magnets. The hopper must only be operated with the quick emptying flap closed.



Notice

For information on the control devices please refer to the separate 'Control Units' operating instructions.

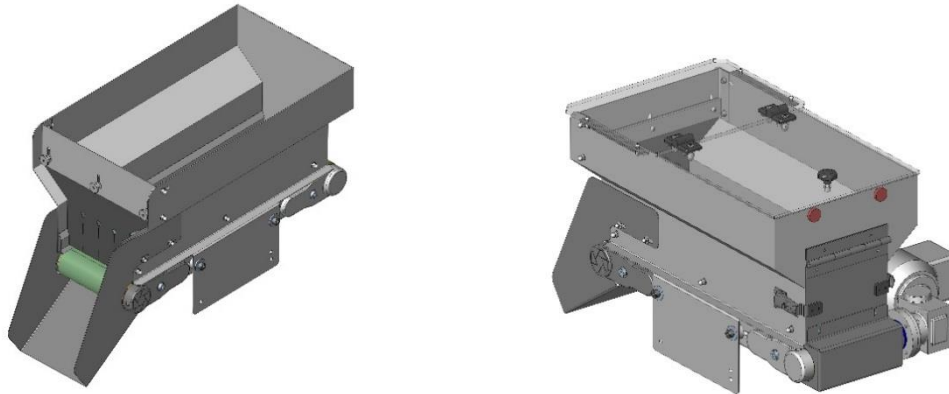

Fig. 1: Belt hopper layout

4. Shipment and installation

4.1. Shipment

Shipment ex works

The belt hoppers are delivered ex works in cardboard or box packaging.

Handling on site

The belt hopper weight depends on its dimensions and motor rating. Please refer to the shipping documents for the weight of your specific equipment.



Attention

Check all guards when unpacking. Replace any damaged parts before commissioning!



Caution

One-piece belt conveyors can be moved to their place of installation on a sufficiently strong trolley or cart.

4.2. Installation

The belt hopper is delivered fully assembled. It can be installed on the RNA supports using an adapter plate or on 40x40 profiles using slot nuts.

4.2.1. Belts



Notice

The standard belts are fabricated with finger joints to create a continuous belt. For such belts the conveying direction can be chosen freely.

For belts with overlap joints the conveying direction should be as shown below.

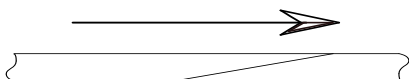

Fig. 1: Choice of conveying direction

Use of the belt for accumulation of parts is an exception. In this case, turn the belt.

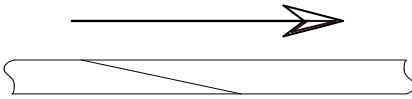

Fig. 2: Accumulation belt conveying direction

4.2.2. Roller alignment

Align the drive and return rollers relative to one another and to the conveyor body (Fig. 3).

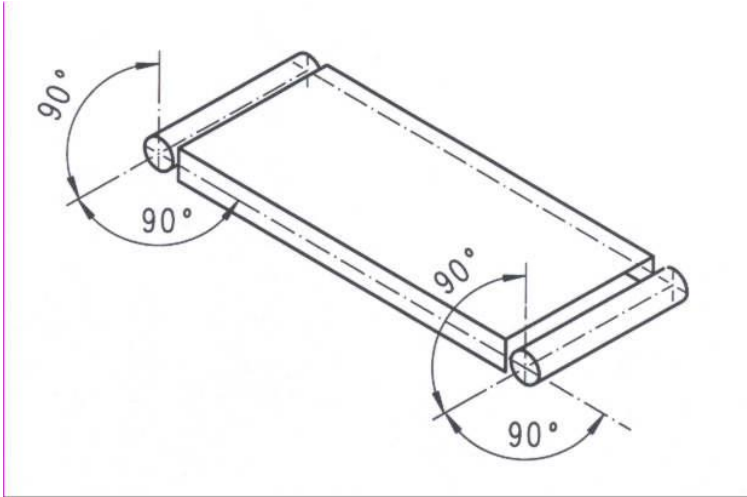

Fig. 3: Roller alignment

4.2.3. Drive system (belt hoppers without RNA control units)

Have a professional electrician connect the motor in accordance with the circuit diagram (see chapter 1). After that, check the sense of rotation.



Attention

Provide suitable overload protection for the motor. The characteristics of the motor can be found on its rating plate.

The belt hopper motor position is steplessly adjustable. To do so, slacken the fixing screw of the motor flange and move the motor into the required position (see Fig. 4). Swing the motor into the position required and re-tighten the fixing screw.

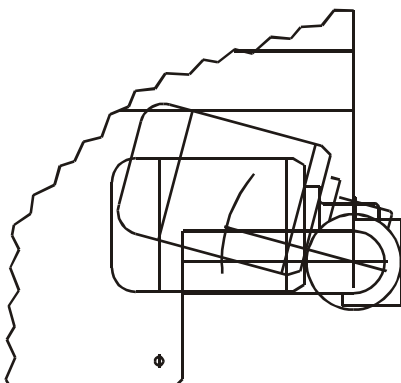

Fig. 4: Steplessly adjustable motor



Caution

Motor protection breakers supplied unfitted must not be installed upside down as this would disable their protective function. Be sure to install the circuit-breakers in the specified orientation.

5. Commissioning



Attention

Electrical connection of the belt hopper must be made by trained professional electricians only! When making any change to the electrical connection be sure to observe the operating instructions for the motor circuit-breaker / control unit.

For starting and stopping the belt hopper use the motor protection breaker fitted beside the motor.

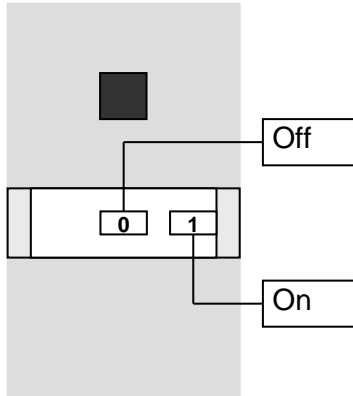

Fig. 5: Motor protection breaker

For belt hoppers with other control units please refer to the separate control unit manual enclosed for operating instructions.

5.1. Belt tracking adjustment

Motor and belt have undergone a trial run and final inspection in the factory. Due to re-installation on site and running-in of the belt it may be necessary to re-adjust belt tracking. This fine tuning is made with the aid of setscrews fitted in the belt return station.

Details of the return station are illustrated below:

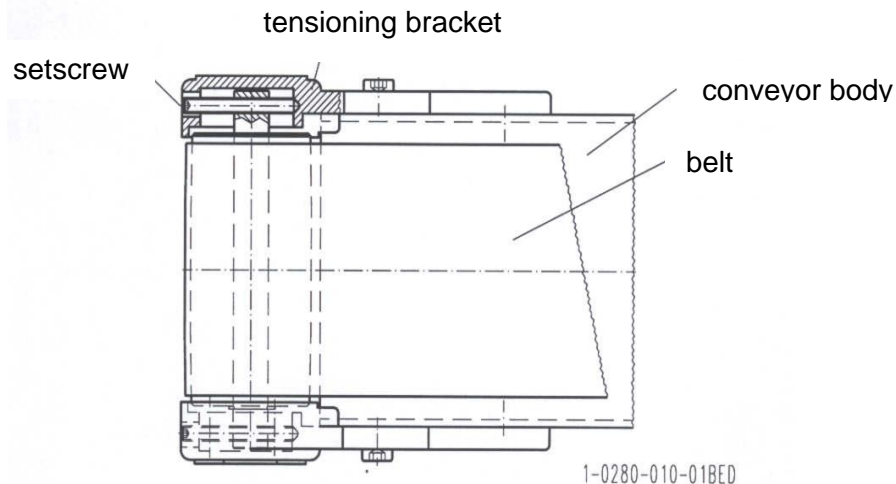

Fig. 6: Belt return station

If the belt runs off-centre after starting of the motor, first make the adjustment in the belt return station. If this is not enough, make the adjustment in the drive station.

5.2. Adjustment of belt return station

- Tighten the setscrew on that side towards which the belt is running (increasing belt tension) or
- slacken the setscrew on the opposite side (decreasing belt tension).



Caution

Too high belt tension may overload both the belt and the motor. After precise adjustment, measure the current drawn by the motor. If it is higher than the value shown on the rating plate, slacken the setscrews uniformly.

After adjustment is completed a trial run over several hours is mandatory. During the first running hours check that the belt runs on line centre at short intervals of time (about 2 to 3 times a day).

6. Maintenance



Attention

For installation, maintenance and repair work all poles of the power supply must be disconnected from the belt hopper in compliance with VDE provisions. Any work on electrical equipment of the belt hopper shall be carried out exclusively by a professional electrician, or by instructed persons (see chapter 2) working under the direction and supervision of a professional electrician, according to electrotechnical rules.

6.1. Belt

Clean soiled belt with spirit and a clean non-linting cloth. Where belts are used for food applications use an approved substitute for the spirit.



Attention

Take care to provide sufficient ventilation! Wear protective clothing.

6.2. Motor

The geared motors require no maintenance for 10,000 operating hours.

Depending on dust accumulation, clean the motor fan cowl, the motor itself and the gearbox housing. This helps to ensure proper cooling of the motor.

6.3. Gearbox

The gearboxes are delivered ready-for-operation with gear oil and grease. This ensures long-life lubrication of all moving components.

No need for dismounting, cleaning and grease change.

6.4. Return, drive and supporting rollers

Clean soiled rollers with spirit and a clean non-linting cloth. Where belts are used for food applications use an approved substitute for the spirit.



Caution

Take care to provide sufficient ventilation! Wear protective clothing.

6.5. Environmental effects

On installation of the belt hoppers take care that belts are not subjected to strong heat radiation. Observe the admissible belt temperatures (see brochure). Otherwise the belts may expand and slip over the drive roller.

Keep oil, chips etc. away from belt conveyors.

7. Spare parts and customer service

For an overview of genuine spare parts available please refer to the separate spare parts list.

In order to make sure that your order is processed swiftly and correctly please specify the device type (see rating plate), the quantity required, the spare part designation and the spare part number.

For a list of Service Center addresses refer to the back cover page of this manual.



Headquarter

Rhein-Nadel Automation GmbH
Reichsweg 19-23
D-52068 Aachen
Tel.: +49 (0)241-5109-0
E-Mail: vertrieb@RNA.de
www.RNA.de

Further RNA group companies:



PSA Zufuhrtechnik GmbH
Steinackerstraße 7
D-74549 Wolpertshausen
Tel.: +49 (0)7904-94336-0
E-Mail: info@psa-zt.de
www.psa-zt.de



RNA Automation Ltd.
Unit C Castle Bromwich Business Park
Tameside Drive Birmingham B35 7AG
United Kingdom
Tel.: +44 (0)121-749-2566
E-Mail: sales@rnaautomation.com
www.rnaautomation.com



HSH Handling Systems AG
Wangenstraße 96
3360 Herzogenbuchsee
Switzerland
Tel.: +41 (0)62-956 10-00
E-Mail: info@handling-systems.ch
www.handling-systems.ch



RNA Vibrant S.A.
Carrer de l'Energia
08940 Cornellà de Llobregat (Barcelona)
Spain
Tel: +34 (0)93-377-7300
E-Mail: info@vibrant-RNA.com
www.vibrant-RNA.com



RNA Digital Solutions GmbH
Reichsweg 19-23
D-52068 Aachen
Tel.: +49 (0)1515-99 28 255
E-Mail: kontakt@rnadigital.de
www.designforfeeding.com
www.rnadigital.de

Further manufacturing sites of the RNA Group:

Lüdenscheid branch

Rhein-Nadel Automation GmbH
Nottebohmstraße 57
D-58511 Lüdenscheid
Tel.: +49 (0)2351-41744
E-Mail: werk.luedenscheid@RNA.de

Ergolding branch

Rhein-Nadel Automation GmbH
Ahornstraße 122
D-84030 Ergolding
Tel.: +49 (0)871-72812
E-Mail: werk.ergolding@RNA.de

Remchingen branch

Rhein-Nadel Automation GmbH
Im Hölderle 3
D-75196 Remchingen-Wilferdingen
Tel.: +49 (0)7232-7355-558
E-Mail: werk.remchingen@RNA.de